

VP9/VL9

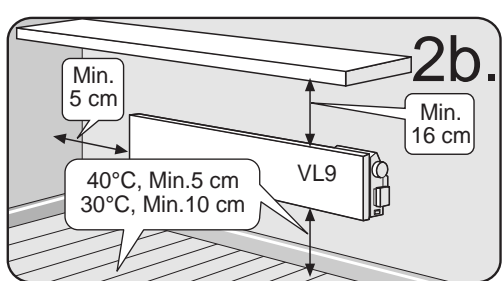
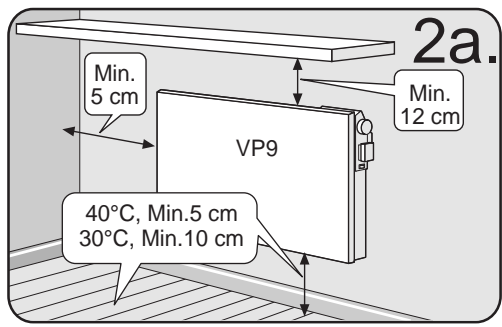
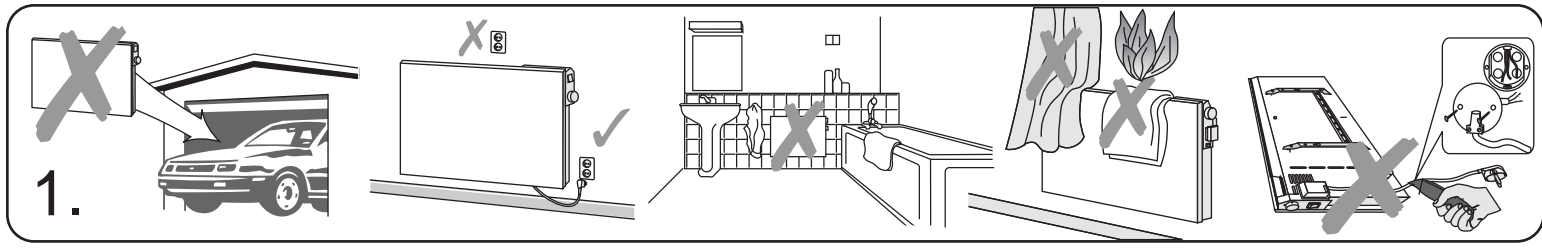

VP (H = 370 mm)

P (W)	L (mm)	A (mm)
400	490	300
600	548	300
800	663	300
1000	720	300
1200	893	600
1400	1013	600
1500	-	-
2000	1353	600

VL (H = 140 mm)

L (mm)	A (mm)
663	300
835	600
1008	600
1238	600
1468	1200
-	-
1813	1200
-	-

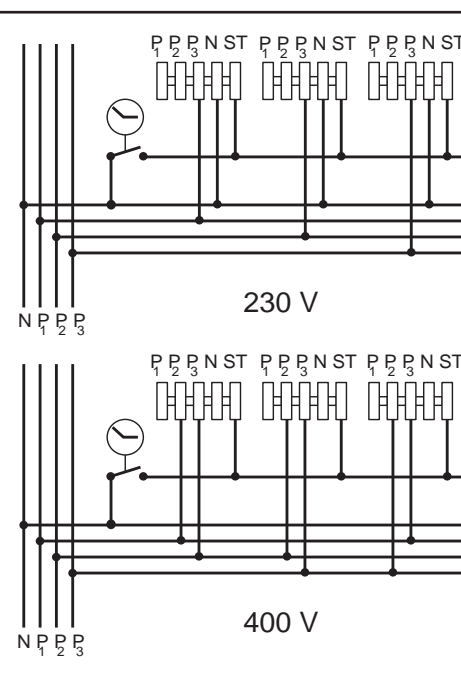
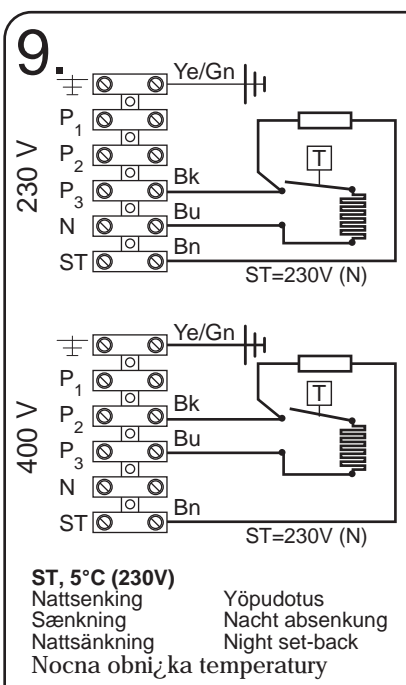
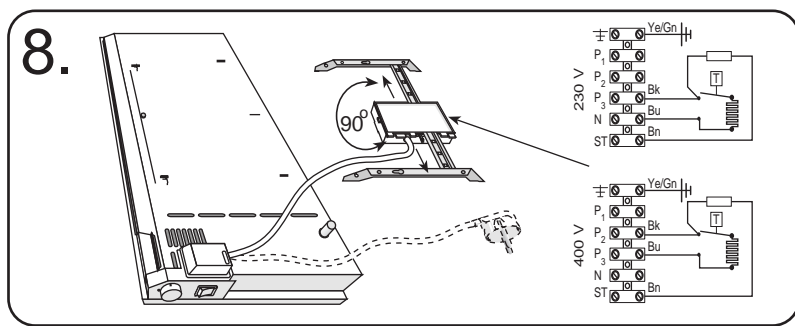
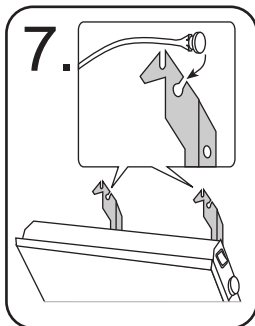
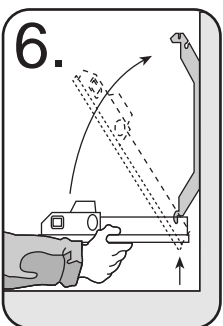
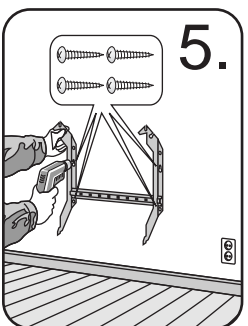
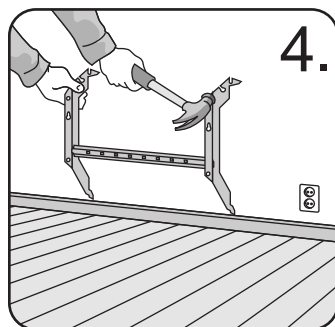
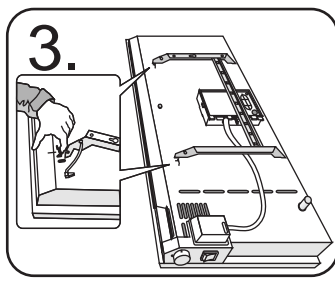

Elektrisk montasje må bare utføres av autorisert installatør.
 Elektrisk montage må kun udføres af autoriseret el. installatør.
 Elektrisk installation får endast utföras av behörig installatör.
 Sähköasennukset saa suorittaa vain asennusoikeudet omaava asennusliike.
 Anschluß darf nur durch Fachmann durchgeführt werden.
 Electric installation must be carried out by an authorised electrician.
 Pod³czenie do sieci elektrycznej nale¿y powierzyæ elektroinstalatorowi.

Bruk
 Brug
 Användning
 Käyttö
 Bedienung
 Use
 Obs³uga

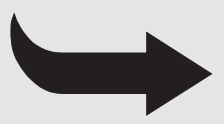

Ye/Gn	Gul/grønn	Gul/Grøn	Gul/Grön	Kelta/Vihreä	Gelb/Grün	Yellow/Green	³oty/Zielony
Bk	Sort	Sort	Svart	Musta	Schwarz	Black	Czarny
Bu	Blå	Blå	Blå	Sininen	Blau	Blue	Niebieski
Bn	Brun	Brun	Brun	Ruskea	Braun	Brown	Br³zowy

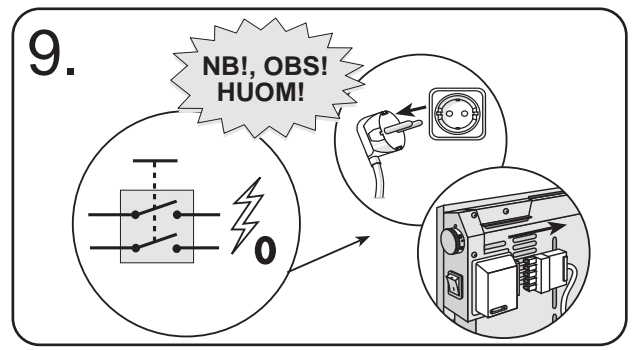
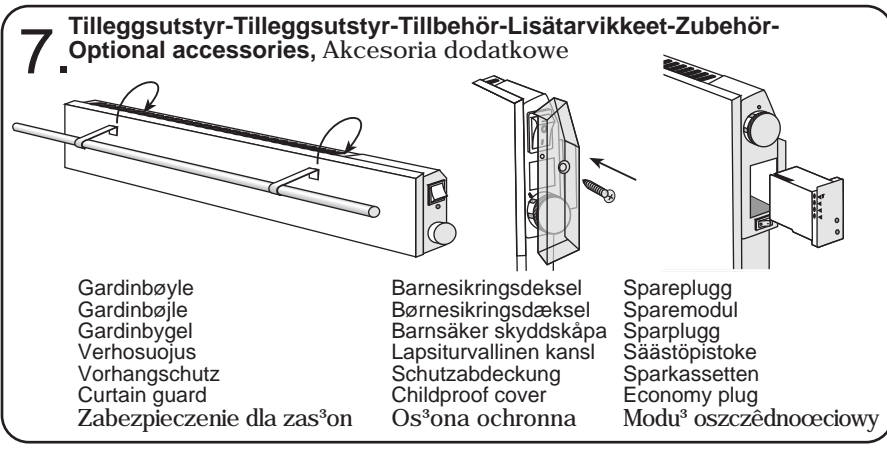
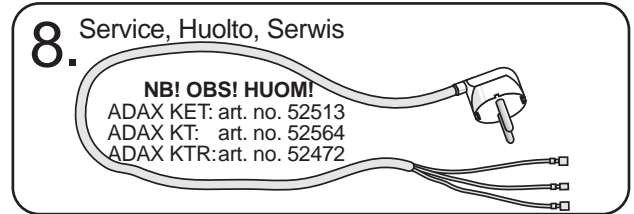
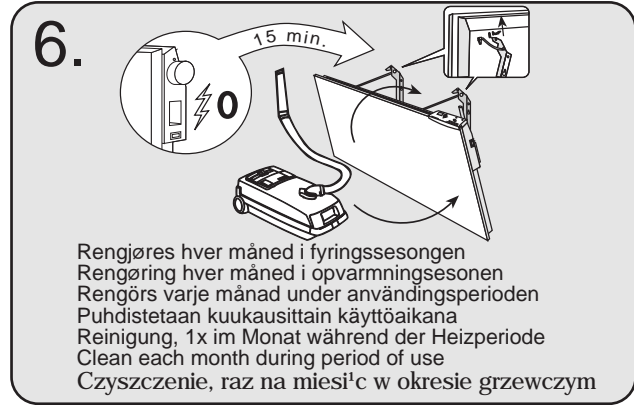
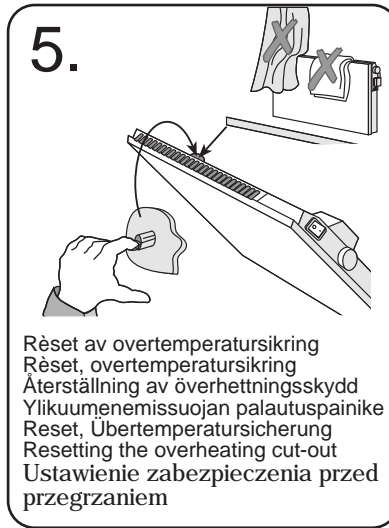
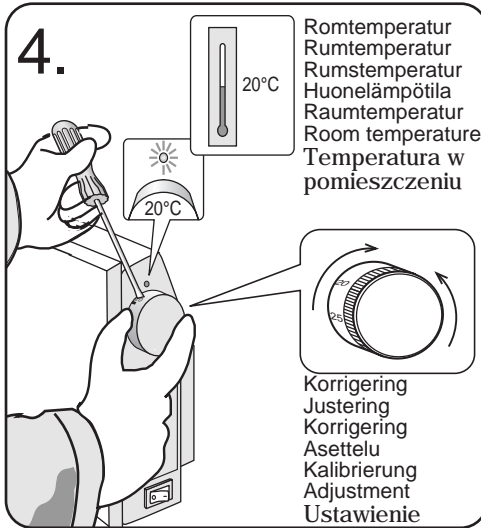
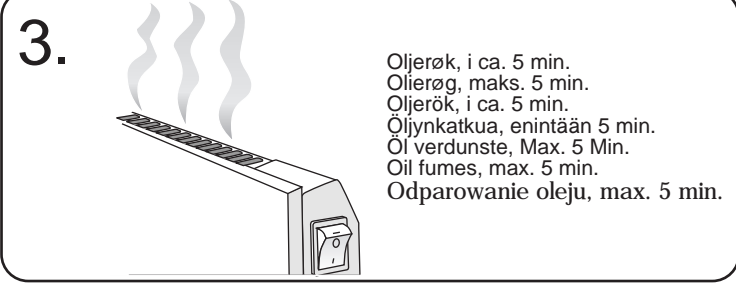
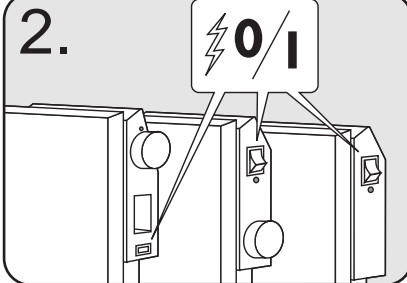
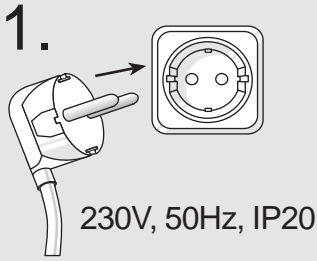

NO Service: Adax Fabrikker A/S 3060 SVELVIK, tlf. 33 772920.
NB! Ta vare på kvitteringen for dokumentasjon av kjøpsdato.

DK Service: ARA-EI A/S Håndværkervej 4, DK-4652 HAARLEV, tel. +45 56286550.
NB! Husk kvittering for købsdato.

SE Service: EI & Digital service AB, Ringvägen 17 S-10273 STOCKHOLM, tel. 08 845180.
OBS! Faktura/kvitto gäller som garantibevis.

FI Huolto: Elektroskandia Oy, Varastokatu 9, 05800 HYVINKÄÄ, puh. 010 222001.
Huom! Säilytä kuitti todistuksena ostopäivästä.

DE Service: Adax Fabrikker A/S N-3060 SVELVIK, NORWEGEN, Tlf. +47 33 772920.
NB! Quittung zum Nachweis des Kaufdatums aufheben.

GB Service: Adax Fabrikker A/S N-3060 SVELVIK, NORWAY, phone +47 33 772920.
NB! Retain the receipt as proof of date of purchase.

PL Serwis: Elektra, ul. Marynarska 14, 02-674 Warszawa, tel. (+22) 8433282
Prosiny zachowae rachunek zakupu oraz kartę gwarancyjn¹.

Montering
Montering
Montering
Asennus
Montage
Installation
Instalacja

Declaration of conformity
We declare under our sole responsibility that this product is in conformity with the following standards:
EN 60 335-1 (1988)+A2+A5+A6+A51+A52+A53+A54, EN 60 335-2-30 (1992)+A51+A52, EN 55014-1 (1997),
EN 55014-2 (1997), EN 61000-3-2/-3 (1995) following the provisions of Directives 73/23/EEC, 93/68/EEC, 89/336/EEC.
Adax-Fabrikker A/S, SVELVIK, NORWAY June 1998.

Tor Åge Kverne
Tor Åge Kverne